

Enhance Audio World through Measurements! System that Matches IT Age

S-265 Audio Analysis System

The S-265 Audio Analysis System has been developed to achieve the best performance and capability, as a standard measuring system for loudspeakers and microphones.

With ETANI's understanding of users' work and requirements, various ideas and new features have been incorporated into our system. We go beyond being an ordinary manufacturer of measuring equipments: Assertions and proposals are given to our system for an ideal audio measurement tool for the future.

The S-265 continues to evolve in the aim to become the best measurement system.



S-265 Customized Model
(8-Channel Simultaneous Measurement)



S-265 Compact Model
(Built-in 20W Power Amplifier)

For Speaker & Microphone Measurements in the Age of DVD

System Features

ETANI's best performing S-265 loudspeaker / microphone measurement system satisfies your demands.

- **High Performance: Broad Band ~100 kHz / High Dynamic Range**
 - Broad Frequency Band 10 Hz ~ 100 kHz
 - High Dynamic Range By 24 bit AD DA, 100 dB or more (FFT)
- **High Stability / High Reliability: Measurements by Digital Signal Processing**
- **Ideal System Configuration for Software Age**

A great combination of a measuring controller, digital signal processor and a personal computer achieves best performance. As illustrated in the diagram below, the test signal generating section and the measuring processing section to process data from microphone and amplifier are separated, so basically, the system can generate any test signals, and can steadily process data coming from couple of sensors. Therefore, by adding new software programs 'new measurements' can be supplemented.

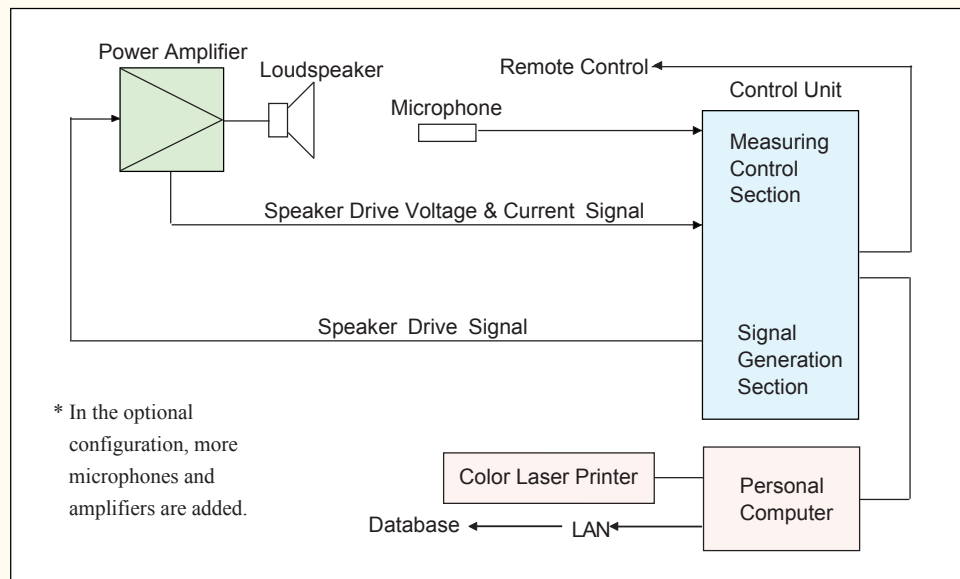

System Diagram

Ideal for Measurement of USB Audio Devices



New S-265U Model

Loudspeaker/Microphone Measurements by USB Connection

Allows you to measure the total characteristics of audio devices with USB interfaces.



NEW S-265U

● Loudspeaker

- SPL Frequency Characteristic
- 2nd / 3rd Harmonic Distortion Characteristic

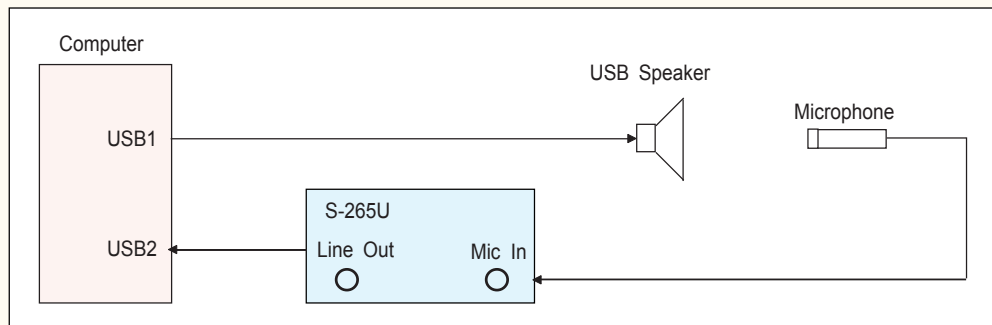

Loudspeaker Measurement

● Microphone

- Frontal Sound Pressure Sensitivity Characteristic
- 90° / 180° Directional Frequency Characteristic

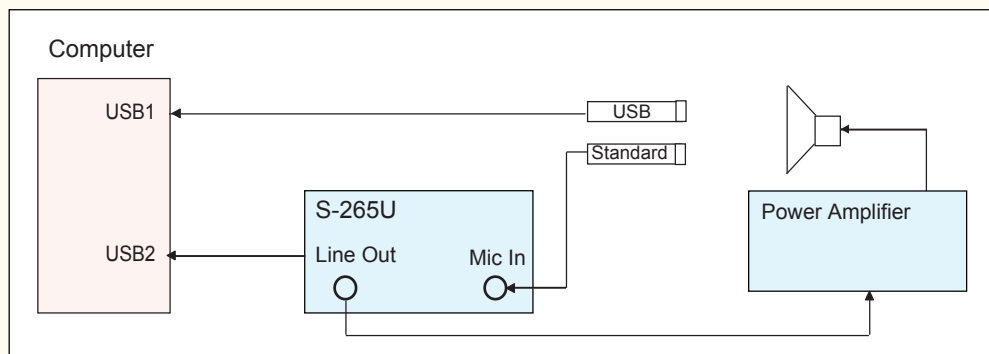

Microphone Measurement

Measures 5 to 9 Curves in One Sweep Measurement

Sweep Measurement

● High-Speed

The S-265 simultaneously measures 5 various frequency characteristics in 1 sweep. The frequency of sine wave, as has been used in the analog measuring systems in the past, is smoothly changed and the power average is calculated per interval that corresponds to the frequency resolution. In the optional configuration, the directivity frequency characteristics of 30°/60° can also be measured. The measuring time is a speedy 15 seconds (7.5 to 60 sec. variable).

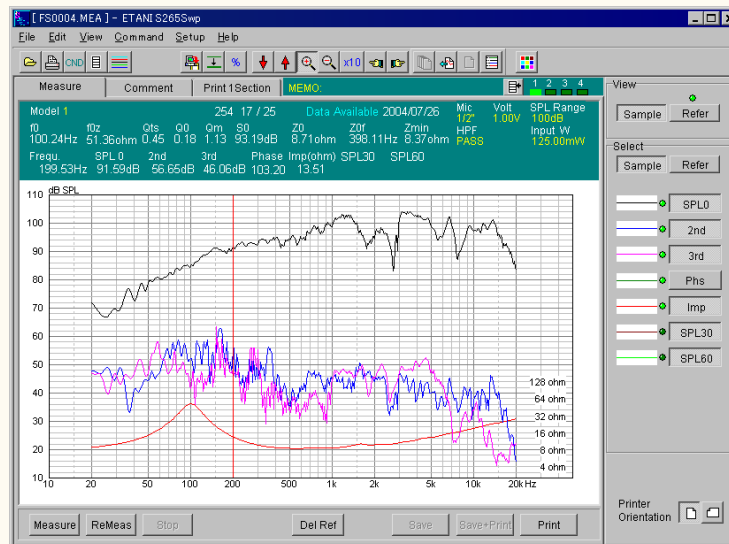

- SPL
- 2nd harmonic distortion
- 3rd harmonic distortion
- Impedance
- Phase
- Directivity simultaneous measurement option:
30° / 60°
Other angles

● One System for All: Covers Various Types of Measurements

In an anechoic chamber that becomes the basis as a measuring room, measurements of frequency characteristics that are frequently used needs to be conducted reliably. On the contrary, there is a demand for being able to cope widely to even measurements that are rarely conducted. The S-265 is capable of operating a variety of measurements through a range of software applications. Therefore, so long as the same sample is set in an anechoic room, various measurements can be sequentially run and extract data.

- Traditional sweep measuring method: Compatibility with the past
- Impulse response measurement: High S/N ratio
- Pink noise measurement
- THD measurement including distortion in the high order, and various others
- Various other options available (see p6 to 10)

Easy-to-Use System

● Software Operation

Conducting measurements through software means that settings, recordings and retrieving former settings are all automated. This stance is consistent with ETANI's initial model when a microcomputer was first introduced to our measurement over 20 years ago. There are no switches or knobs for level setting on the front panel of system.

● Ready to Use

Recall the time when you try to conduct an unusual measurement and set up using an ordinary former model. Recalling how to connect the instrument, actually connecting, checking,... and in the meantime, cables are missing, for instance. Moreover, you have finished connecting but next, how to operate it, and checking the operation... In the end, rather than the time taken to measure, the preparation is more difficult. The S-265 is delivered to the customer as a system inclusive of all cable connections so that you can measure without any difficulty.

● Data Application / Database

Before, when data was printed and recorded, the work was finished. Data was merely to see. ETANI aspires to exploit the advantage of computer as much as possible and enhance data application. Consequently, ETANI has designed a system that enables engineers to easily work on their desks and reapply data, allowing a practical data application via LAN and database. Data can be compared at any time, ideas can be consolidated and reports can be made. Data Viewer automatically enters/renews measured data to the server and viewed from PCs via LAN.

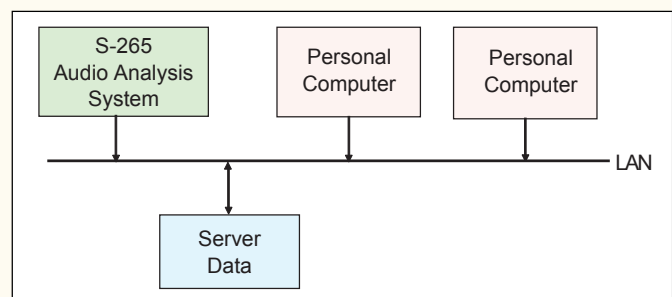

Data Viewer

● Application of Data

- | | |
|-----------------|---|
| Quality Control | <ul style="list-style-type: none">• Data storage and maintenance• Automatic record of calibration data• QS-9000 / ISO-9000 compatible |
| System Design | <ul style="list-style-type: none">• Data search• Comparative/examining tools• Produce documents / Quick prints in B & K chart• Import and display outside data in CSV form• Output data for customers and for use in other sections |

With Understanding of Users' Work & Requirements

● Octave Band Characteristics

This is a frequency response measurement using pink noise. In a noise measurement, there arises a variation in the measuring values, however, steps are taken to reduce this even for low band to gain stable measured values in a short time.

- Frequency resolution: 1/3, 1/6, 1/12 oct.
- Limit curve display
- Deviation value (dB) display in relation to the levels in the specified frequency band

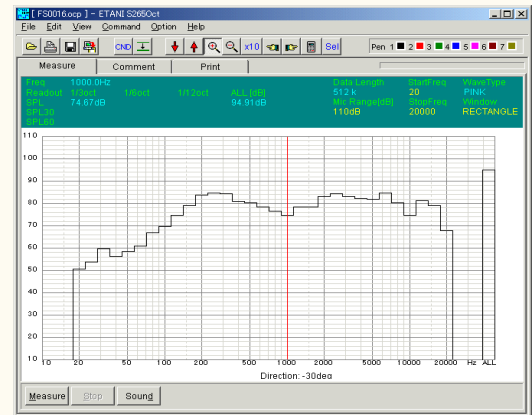

● Directivity Characteristics

This is the directivity characteristics software. The following 2 types of graphs can be utilized. The measurement is conducted with a standard microphone moving instrument.

• Polar Pattern:

A fixed frequency data is shown in a circular graph.

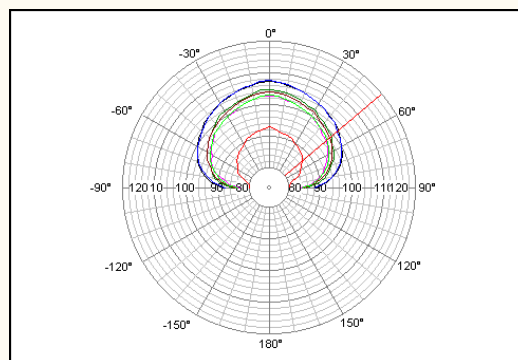

Polar Pattern

• Cumulative 2π:

A wide angle range of frequency characteristics is shown in 3D.

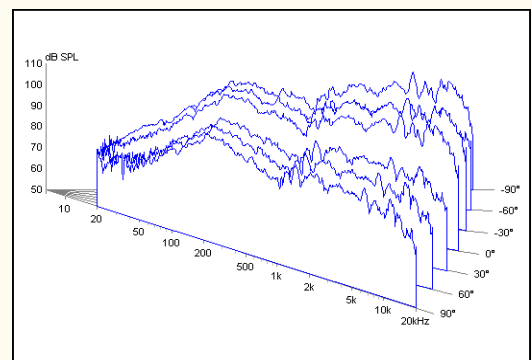

Cumulative 2π

● Spot Frequency THD/IMD Measurement

10 series of statistical processing can be conducted. (See image on previous page)

● Statistical Processing Software

Mass production tests and measured data of test samples can be statistically processed. The efficient data handling can aid the work in the design and the quality control sections. Software can be suited to the various needs of the user.

1. Statistical Processing of SPL Frequency Response

- Mean, maximum, minimum and dispersion, etc.: Provide references for limit curves
- Closest to the mean are ranked in the order: Standard samples and user- defined samples can be determined automatically.
- The mean curve and other extracted data can be applied for the use of catalogs, etc.

2. Statistical Processing of All Frequency Responses and Automatic Limit Curve Creation

- Extended features of statistical processing explained earlier.
- Adds preset margins and creates limit curves automatically: Curves close to hand-drawings can be created due to the smoothing function.
- Various numerical data can also be statistically processed: sensitivity, f_0 , impedance & Q_0 , etc.

3. Creation of Moving Average Curve

- Calculates and creates curves that were moving averaged on the frequency axis.
- The function is in conformity to the speed of previous analog measuring systems.

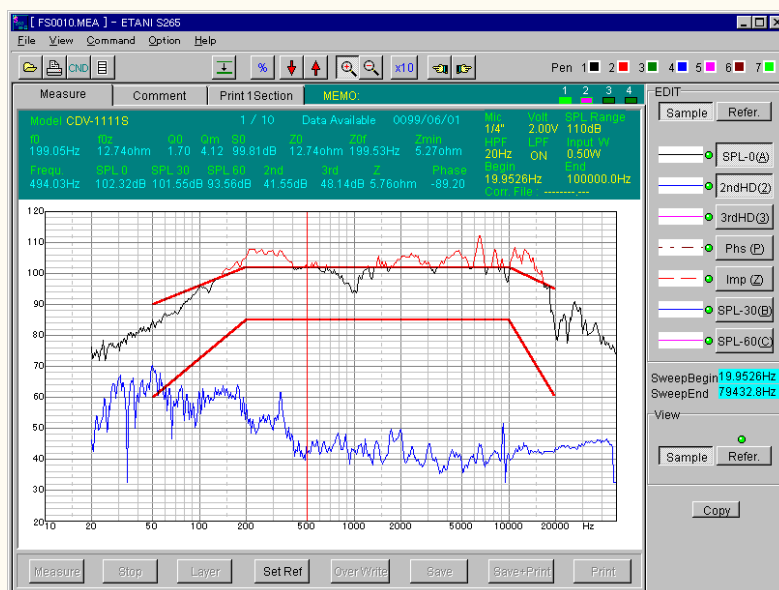

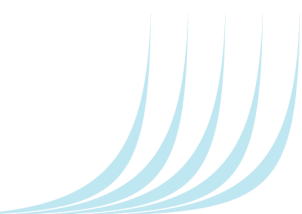

● **IMD (Inter-Modulation Distortion)**

Frequency characteristics of intermodulation distortion are calculated (SMPTE method).

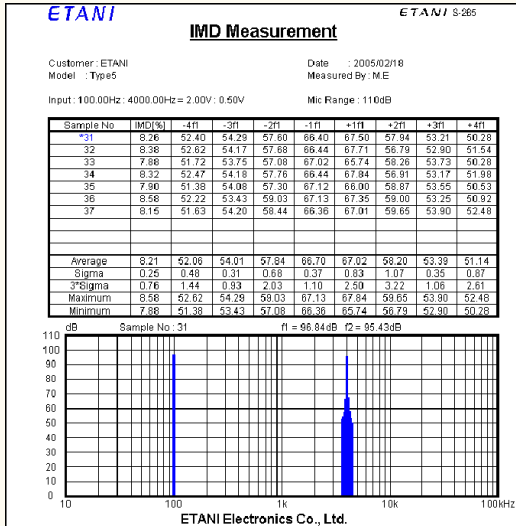

Individual Sample View

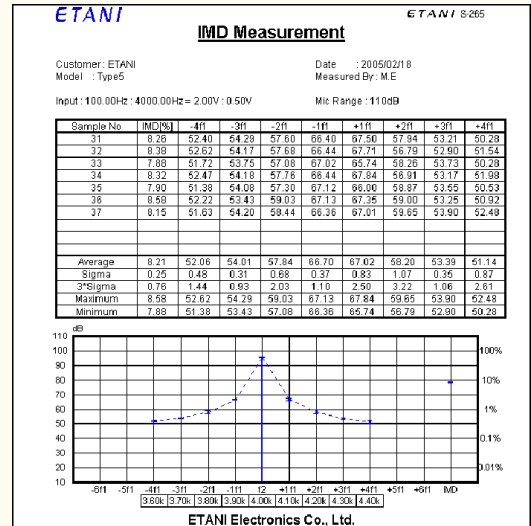

Statistical Processing View

● **IMD Sweep**

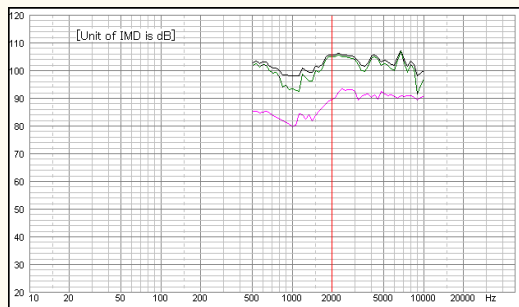

● **Tone Burst**

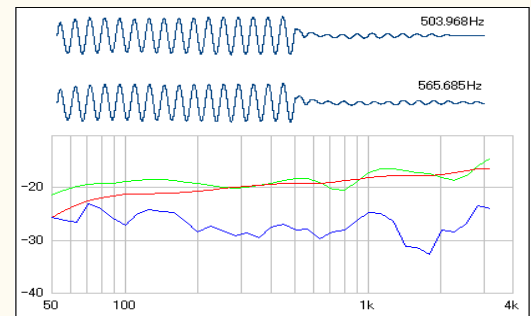

● **Measurement Methods for Evaluating Automobile Speakers for USA**

• **Hi-2 Measurement**

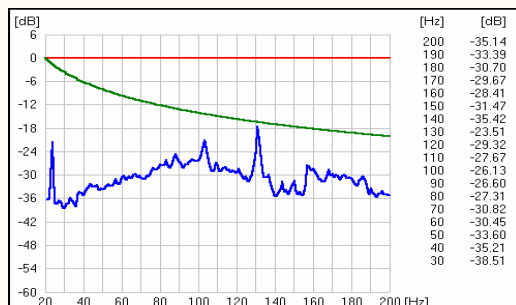

• **CW-IMD**

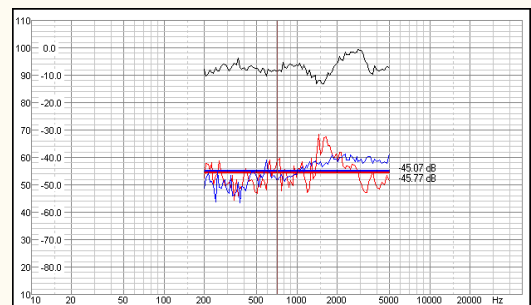

● Impulse Response Measurement

- FFT analysis
- High S/N ratio measurement:
Hi-power measurement by noise and numerous cumulative averaging.
- 3D waterfall display:
Observation of transient response
Spectrum change over time

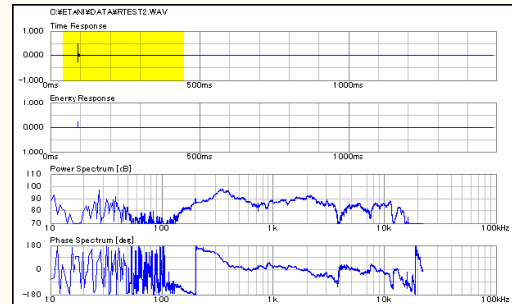

● Multi-Impulse

The waveform outputted from a loudspeaker is recorded at various points by shifting the microphone position. The shift of wave surface over time is displayed on the graph.

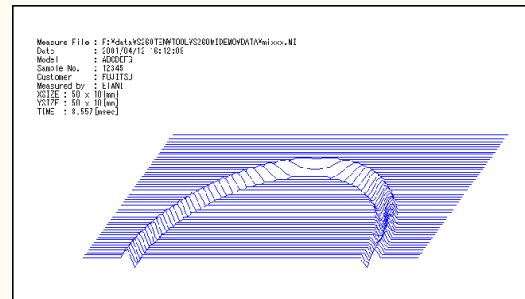

● Power Linearity Measurement

Input level vs. distortion ratio is measured.
Short-time frequency response measurement.

● Total Data Viewer

- Enables use in the staff room using LAN
- Database search function
- Display & comparison of measured data
- Import of external data: CSV format
- Viewer can be opened while measuring

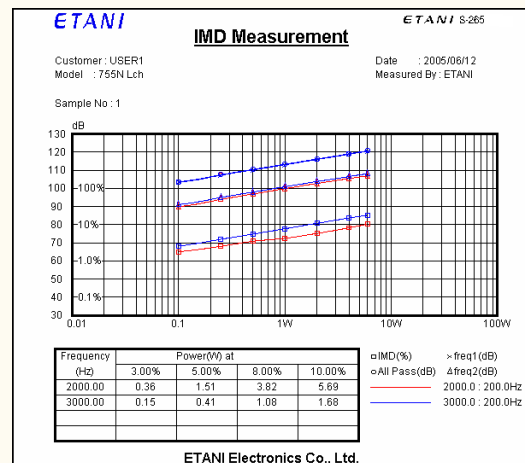

● Others

- Combi Measurement: Automatic combination of various measurements
- Microphone measurement
- Measured data export to spreadsheet applications
- DXF data output, etc.

Recommended System Compositions that Matches Users' Needs

Recommended Composition: Types & Usages

- Standard Version



(2 Measuring Units + 50W Power Amplifier)

- Compact One-Body Type



Smallest, light-weight Basic Model (20W Amplifier inside)

- 50W Power Amplifier Set



(Top: Measuring Unit Bottom: 50W Amplifier)

- 100W Power Amplifier Set



(Top: Measuring Unit Bottom: 100W Amplifier)

- Customized Model



8-channel simultaneous measurement possible
(System rack is optional)

S-265 Specifications

MAIN SYSTEM

Measurements & Tests	1) Sound Pressure Level (SPL) Frequency Response (30°, 60° & any degree simultaneous measurement option available) 2) Harmonic (2nd & 3rd) Distortion Frequency Response 3) Impedance Frequency Response 4) Phase Frequency Response: Calibration according to distance 5) Sensitivity (So) 6) Resonance Frequency (Fo) 7) Impedance (Zo) * Standard model measures 5 frequency characteristics (option: up to 9) simultaneously in 1 sweep.
Frequency Range	10 Hz ~ 100 kHz *User-definable setting
SPL	
Range	70 ~ 160 dB SPL in 10 dB steps (with microphone sensitivity: -36 dBV/Pa)
Max. Measuring Range	20 ~ 168 dB SPL (depends on microphone performance)
Accuracy	± 0.1 dB at 1 kHz
Frequency Response	± 0.2 dB 20 Hz ~ 20 kHz ± 0.5 dB 10 Hz ~ 100 kHz
Distortion Measuring Range	Below - 70 dB (SPL: 90 dB range when using sweep test)
Impedance	
Range	0.5 ~ 200 Ω (automatic range)
Accuracy	± 1 % / 1 ~ 50 Ω ± 2 % / 0.5 ~ 1, 50 ~ 100 Ω ± 5 % / 100 ~ 200 Ω (1 kHz)
Dynamic Range	
A/D Converter	24 bit
Sampling	220 kHz
Drive Power & Voltage	
Max. Power	50 W (2 ~ 8 Ω) / standard 100W (0.5 ~ 8 Ω) / high power 20W (4 ~ 8 Ω) / compact one body type If combined with an amplifier on the market, a greater power measurement possible. Please inquire.
Voltage Range	0.01 ~ 20 V / standard 0.01 ~ 28 V / high power 0.01 ~ 13 V / 20 W
Frequency Response	± 0.2 dB / 20 ~ 20 kHz ± 0.3 dB / 10 ~ 20 kHz ± 1 dB / 20 ~ 50 kHz ± 1.5 dB / ~ 100 kHz at 1 W * The above speaker drive voltage deviation can be denied by automatic calibration. Speaker cable inclusive.
Sweeping Time	Standard 15 sec.: 20 Hz to 20 kHz Changeable
Frequency Accuracy	± 0.05 %
Frequency Resolution	1/48 oct. (160 points / 10 x frequency) 20 Hz ~ 20 kHz: 481 points
Software	1) Measuring Conditions / Data Management / Directory Control possible 2) Sweep Measurement 3) Measured Data Record 4) Graphs Overlapping Display (User flexible overlapping layers and standard layers: Both possible) 5) Data File Output (CSV: standard DXF: option) 6) Calibration (SPL, voltage & impedance) * Graph horizontal/vertical ratio Vertical: 10 dB / 20 mm/10 mm, 2 types Horizontal: 50 mm / 10 x frequency
Power	AC100 V ~ 240 V 50 ~ 60 Hz (according to inner setting)
System Configuration	1) Measuring Unit 1 ~ 4 pcs (depending on measuring feature options) 2) Power Amplifier 1 pc (compact one body model with measuring unit available) 3) Remote Control Unit 1 pc 4) Cables 1 set (speaker cable: 5 ~ 10 m) 5) Sweep Measuring Software 1 set

Specifications subject to change without notice.



ETANI

Etani Electronics Co., Ltd.

1-10-15 Ohmori-Honcho, Ohta-Ku, Tokyo 143-0011, Japan

TEL.+81-3-5763-1391 FAX.+81-3-5763-1394

<http://www.etani.co.jp/eng/>